

SKOOKUM®

Guaranteed Tough Since 1890

Connecting Link Series



- Grade 8 & 10
- Design Factor 4:1
- Reliable & Durable
- Drop Forged Alloy
- Fatigue Tested per EN 1677-4
- Easily connect components to slings

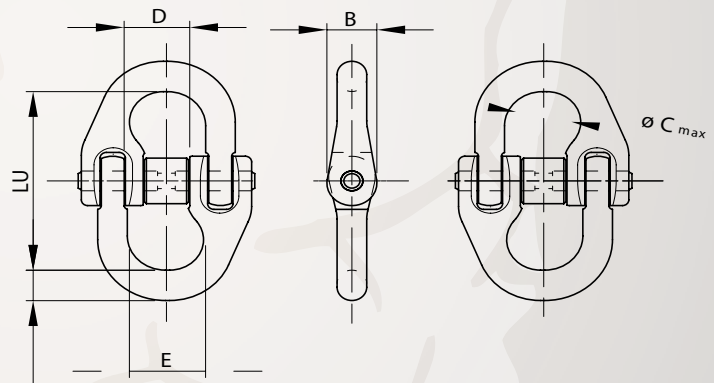

SPECIFICATIONS

ALLOY STEEL GRADE 8	CHAIN IN.	PART #	WLL ¹ (LBS)	WEIGHT (LBS)	PACKAGED QTY
	.75	1810208R	28300	4.20	1
	.875	1810228R	34200	7.00	1
	1.0	1810268R	47700	10.80	1
	1.25	1810328R	72300	18.20	1

DIMENSIONS (IN)

A	B	C	D	E	LU
.75	1.00	1.3125	1.5625	1.75	2
.875	1.125	1.50	1.75	2.00	2.25
1.00	1.25	1.875	2.00	2.125	2.5625
1.25	1.50	2.4375	2.25	2.6875	3.125

HIGH ALLOY STEEL GRADE 10	CHAIN IN.	PART #	WLL ¹ (LBS)	WEIGHT (LBS)	PACKAGED QTY
	.25	281006HB	3100	.20	30
	.3125	281008HB	5700	.40	30
	.375	281010HB	8800	.70	20
	.50	281013HB	15000	1.50	1
	.625	281016HB	22600	2.50	1

A	B	C	D	E	LU
.28125	.4375	.50	.625	.6875	1.75
.50	.625	.6875	.8125	.875	2.1875
.5625	.75	.875	1.00	1.125	2.6875
.75	1.00	1.00	1.1875	1.375	3.75
.875	1.125	1.25	1.4375	1.625	4.0625

ORDER TODAY!!!

PHONE 503.982.9779 • SALES_TEAM@ULVENCOMPANIES.COM

